

Codice: 30MR

Titolo: Inseguitore fotovoltaico 30MR

Note: con pistone

Scala: 1:50 (1:100)

Numero pezzi: 1

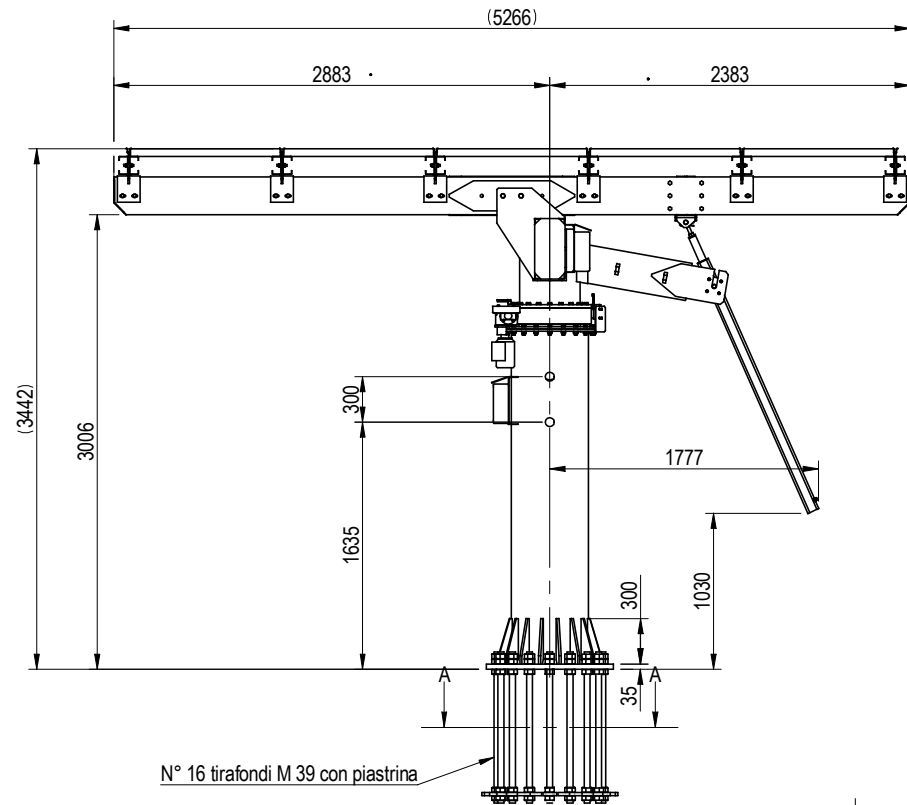

N° 16 tirafondi M 39 con piastrina

Inseguitore orizzontale  
1:50

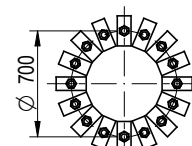

Sezione A-A

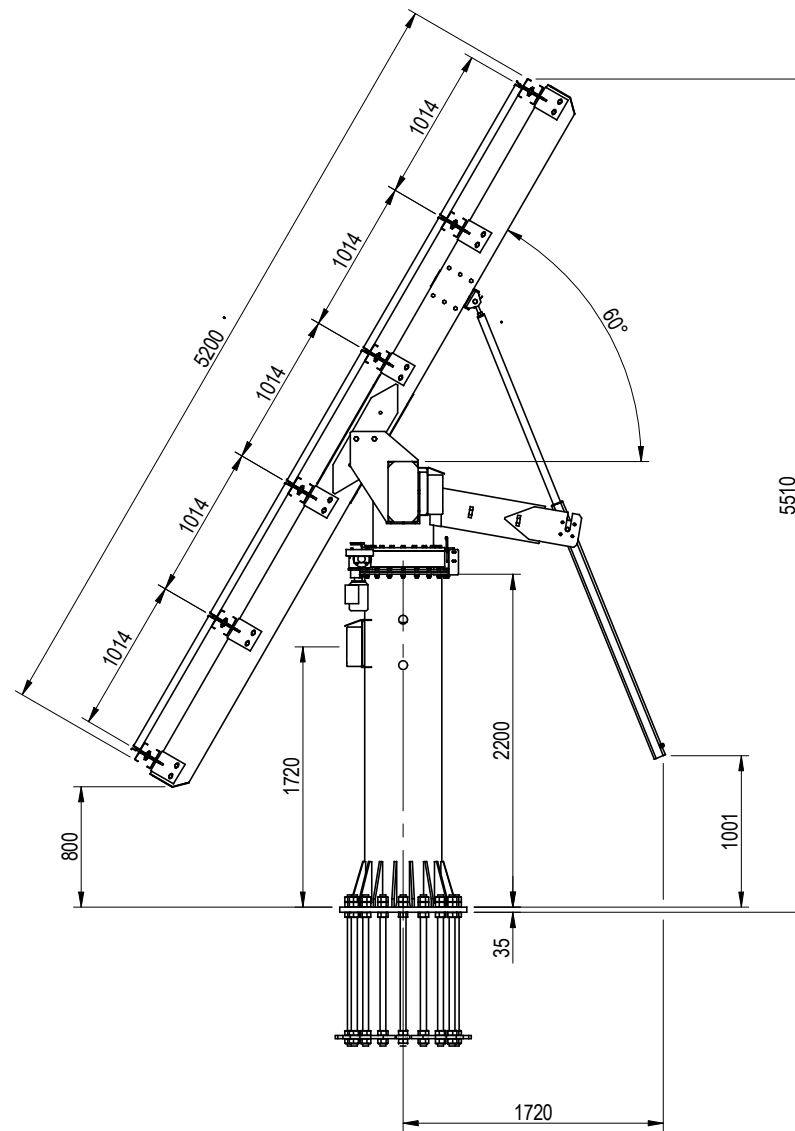

Inseguitore inclinato di 60°  
1:50

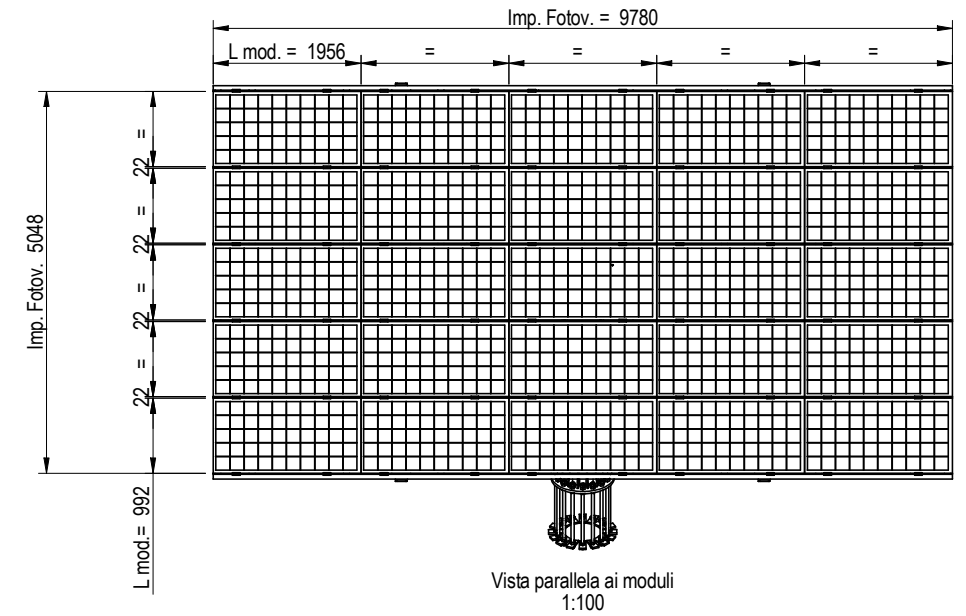

Vista parallela ai moduli  
1:100

DATE	No.	REVISION	BY
------	-----	----------	----

Connections  
Nuts and Bolts : 8.8 class galv. "DACROMET"  
Welds : MAG or basic electrode as UNI 10011

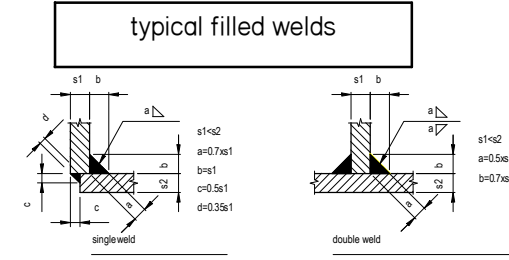

Thickness of the welds have to be equal to the minimum thickness of the pieces to be join where is not indicated differently.

NORMATIVE DI RIFERIMENTO:  
UNI 4600 Indicazione delle rugosità sui disegni  
UNI 7070 Acciai non legati per impieghi strutturali  
UNI EN 22553 Rappresentazione simbolica delle saldature sui disegni  
UNI EN 10025 Acciai non legati laminati a caldo

**MECH srl**  
Via Pasteur, 16 - Reggio Emilia  
Tel. 0522/332903 - FAX 0522/1710466  
E-mail: info@strutture.info

**Scale :**  
See views

<b>Total:</b>	Date: 26/01/2010
<b>Title:</b> Ingombri Inseguitore 30MR Orizzontale e a 60°	Proj.: Menozzi Ing. Stefano Desig.: RNI
<b>Details n°:</b>	Drawing n° 30MR02
<b>File's name:</b>	Revision n° 0